

### GENERAL FEATURES:

Unidirectional wafer type knife gate valve with monoblock body

Connexion PN16/PN10 (DN50 - DN150), PN10 (DN200 - ...)

Provides high flow rates with low pressure drop

Designed for: - water, liquids and gas, lightly polluted with solid material (max. 5%)

- pneumatic transport of powders

- paper pulp with low concentration



TESTS AND CERTIFICATES	
PED/CE	2014/34/UE
Machinery directive	DIR 2006/42/EC
Atex	Group II, categorie 3 GD
Testting procedure	EN-12266

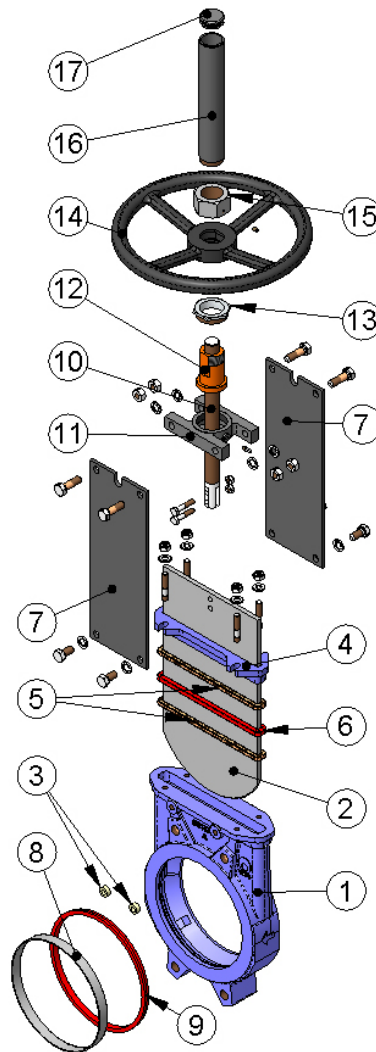

Pos.	Description	Materials
		Version in stainless steel MXT-A1V110000
1	Body	A 351 Gr. CF8M
2	Gate	AISI 316
3	Guide	UHMWPE (RCH 1000)
4	Packing gland	A 351 Gr. CF8M
5	Packing	RPTFE
6	O-ring seal	EPDM
7	Support plates	S275JR
8	Ring	AISI 316
9	Seat	Metal
10	Stem	AISI 303
11	Yoke	Steel
12	Stem nut	Bronze
13	Lock nut	ST44.2 + Zinc
14	Handwheel	Nodular cast iron
15	Nut	Steel
16	Stem protection	Steel
17	Top cap	Plastic

### Kv Values

Ø	DN	Kv
2"	50	206
2 1/2"	65	305
3"	80	485
4"	100	895
5"	125	1550
6"	150	2095
8"	200	3834
10"	250	5375
12"	300	8083
14"	350	10700
16"	400	14200
18"	450	18405
20"	500	23215
24"	600	34142
28"	700	46440
32"	800	61490
36"	900	79985
40"	1000	99750

### Max. differential pressure (bar)

Ø	DN	ΔP
2"	50	10
2 1/2"	65	10
3"	80	10
4"	100	10
5"	125	10
6"	150	8
8"	200	7
10"	250	5
12"	300	5
14"	350	4
16"	400	4
18"	450	3
20"	500	3
24"	600	3
28"	700	2
32"	800	2
36"	900	2
40"	1000	2

**MATERIALS:**

-Handwheel in nodular iron

**OPTIONS:**

- Locking devices
- Extensions: stand, pipe, plates
- DN higher than those given in the table

**INCLUDING:**

- Handwheel
- Stem
- Nut
- Stem protection hood

**REMARKS:**

-From DN 600, the actuator is with gears

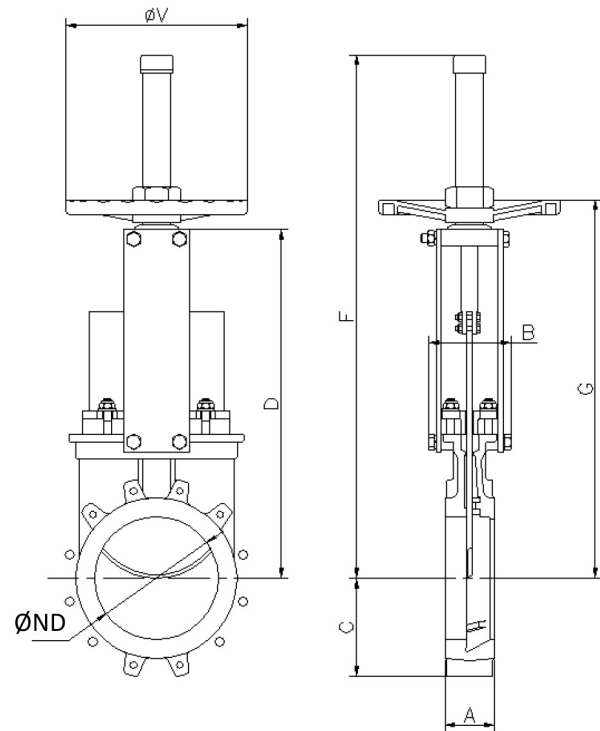

**Dimensions** (in mm)

Ø	DN	A	B	C	D	F	G	ØV	Kg
2"	50	40	92	63	241	409	280	225	7
2 1/2"	65	40	92	70	268	436	307	225	8
3"	80	50	92	92	294	469	333	225	9
4"	100	50	92	105	334	502	373	225	11
5"	125	50	102	120	367	585	406	225	13
6"	150	60	102	130	419	644	458	225	17
8"	200	60	119	160	525	815	578	325	28
10"	250	70	119	198	626	1016	679	325	40
12"	300	70	119	234	726	1116	779	380	56
14"	350	96	290	256	797	1336	906	450	94
16"	400	100	290	292	903	1442	1012	450	116
18"	450	106	290	308	989	1628	1098	450	162
20"	500	110	290	340	1101	1738	1210	450	191
24"	600	110	290	400	1307	2046	1416	450	264
28"	700	110	320	453	1506	-	-	-	441
32"	800	110	320	503	1720	-	-	-	568
36"	900	110	320	583	1953	-	-	-	736
40"	1000	110	320	613	2137	-	-	-	921

**Connection DIN**

Ø	DN	●	○	Metric	P	ØK
2"	50	4	-	M16	8	125
2 1/2"	65	4	-	M16	8	145
3"	80	4	4	M16	9	160
4"	100	4	4	M16	9	180
5"	125	4	4	M16	9	210
6"	150	4	4	M 20	10	240
8"	200	4	4	M 20	10	295
10"	250	6	6	M 20	12	350
12"	300	6	6	M 20	12	400
14"	350	10	6	M 20	21	460
16"	400	10	6	M 24	21	515
18"	450	14	6	M 24	22	565
20"	500	14	6	M 24	22	620
24"	600	14	6	M 27	22	725
28"	700	16	8	M 27	22	840
32"	800	16	8	M 30	22	950
36"	900	20	8	M 30	20	1050
40"	1000	20	8	M 33	20	1160

- Blind tapped holes
- Through holes

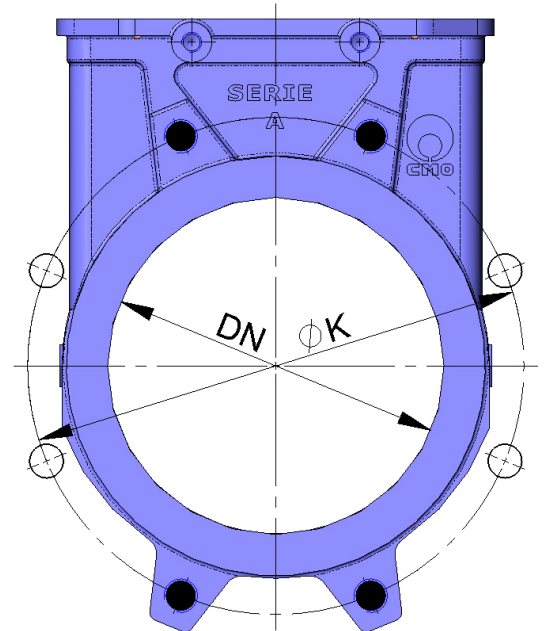

**Connection ANSI**

Ø	●	○	R UNC	P	ØK
2"	4	-	5/8"	8	120,6
2 1/2"	4	-	5/8"	8	139,7
3"	4	-	5/8"	9	152,4
4"	4	4	5/8"	9	190,5
5"	4	4	3/4"	9	215,9
6"	4	4	3/4"	10	241,3
8"	4	4	3/4"	10	298,4
10"	6	6	7/8"	12	361,9
12"	6	6	7/8"	12	431,8
14"	8	4	1"	21	476,2
16"	10	6	1"	21	539,7
18"	10	6	1 1/8"	22	577,8
20"	14	6	1 1/8"	22	635
24"	14	6	1 1/4"	22	749,3
28"	20	8	1 1/4"	22	863,6
30"	20	8	1 1/4"	22	914,4
32"	18	10	1 1/2"	22	977,9
36"	20	12	1 1/2"	20	1085,9
40"	24	12	1 1/2"	20	1200,2

- Blind tapped holes
- Through holes

